



The all new ARTY75H

The system that will not let YOUR customers down

Everything you need is included
Easy clean designs
High speed
Engineered for Amazing Flexibility
10 to 400 packages per minute



Simple user friendly Touch screen with pre-programmed set-up teacher



We at ARTYPAC take great pride in supplying our customers with the simplest most dependable fully automated systems on the market.

Made to handle:

Breads - Candies
Croissants - Muffins
Collection Cards
Doughnuts- Biscotti's
Fire Logs - Industrial
Parts - Frozen Foods
Chocolates Pies
Danishes - Fruits and
Vegetables - Waffles
Bagels - Puff Pastry
Date Squares - Mille
Feuilles- Buns - Moon
pies - Pancakes
Sandwiches - Diner
rolls - Marshmallow
Treats and more



Visit our youtube channel at:
<https://www.youtube.com/user/artypacautomation>

3315 Boul. Industriel
Laval, Quebec
H7L 4S3

Phone: 450.668.6600
Toll free: 877.768.6600
Fax: 450.668.6633
E-mail: info@artypac.com

www.artypac.com

MADE IN CANADA BY :



Beyond Expectations since 1996

The NEW ARTY 75H

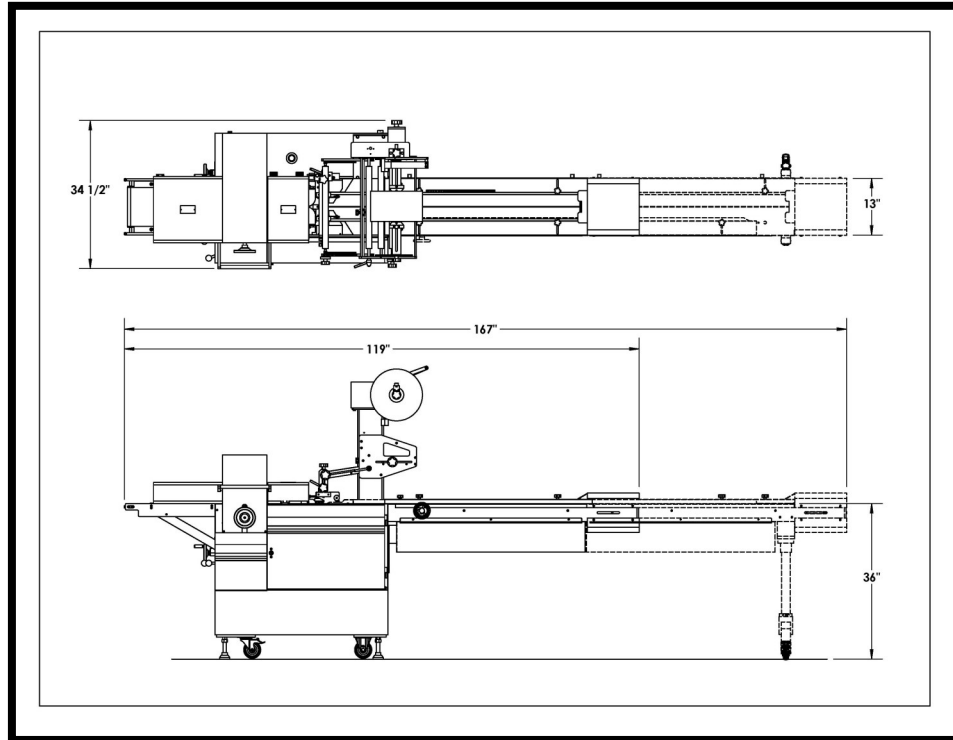

FEATURES

- Industry leading "teacher" Touch Screen HMI
- 4 Minute Set-ups
- Quick loading, self-centering, reel holder
- Adjustable bag forming box
- Cut-off length adjustment by means of a hand wheel and a mechanical variator or optional Servo Drive
- Fin seal folding to the left or to the right
- Variable speed by means of a potentiometer
- PLC controlled
- Digital PID temperature controllers
- Jaws drive torque limiter with safety switch and reset hand wheel
- Lugged infeed conveyor equipped with quick release electromagnetic clutch
- Polycarbonate safety guards with interlock safety switches.
- Easy print registration

Available with fully integrated automatic aligning and spacing infeed Smart Conveyor

TECHNICAL DATA

Bag length*:	Min. ---1 3/4"	Max. ---24"
Bag width:	Min. ---1"	Max. ---7"***
Reel size:	Max width.	18"
	Max. OD	12"
	Core	3"
Speeds up to: (bags per minute)	Single jaw :	125
	Double jaws:	220
	Quadruple jaws:	400
Power supply:	220/110 V, 10 A, single phase	

*The ratio from min. to max. is 1/3

***8" with optional 9" wide cross sealing jaws.